

Installation & Wiring Instructions

TLP/1S/TP40-R

Two Part Remote Conversion Kit



PLEASE READ THESE INSTRUCTIONS BEFORE COMMENCING INSTALLATION & LEAVE WITH END USER

Description:

The Liteplan range of TLP/1S/TP40 modules are designed to convert a wide range of LED types with one main version. The TLP/1S/TP40 is the popular choice for converting most standard LED luminaires and arrays from 50 to 300 Volts. The modules are designed to be installed into the low voltage connection between the mains driver and the LEDs and allows the LEDs to be operated as normal under mains healthy conditions and operated at reduced light output in emergency. The modules automatically adjusts the output current to provide the best match between the battery and the load, providing maximum illumination whilst ensuring full battery duration and are compatible with a wide range of lighting. The unit will recharge the batteries after the test of clause 22.3 of BS EN 61347-2-7:2012. The battery is fitted with a PCM to protect the supply voltage against reverse polarity.

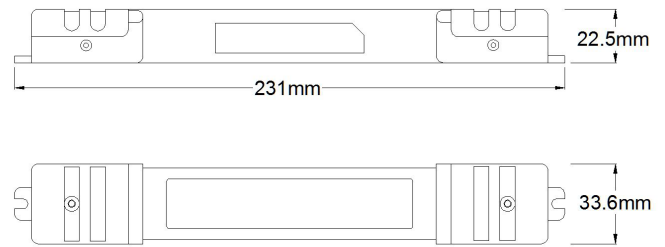

Fixing Centres 224mm

TLP/1S/TP40-R

Rated - 2.4W
I_{rated} - 48-7mA
Voltage Range 50 - 300 Volts
Open Circuit Voltage (U-OUT)=350 Volts

Specification:

Input Voltage	230-240 Volts AC 50/60 Hz
Power Rating (Charging)	2.5W - 15mA - $\lambda = 0.7$
Insulation between supply & battery	Double Reinforced
Duration	3-hours
Ambient Temp. Ta	0°C to + 35°C
Max Case Temp. Tc	70°C
Max Battery Temperature	55°C
Recharge Period	24-Hours
Battery Type	3.2V 4.8Ah LiFePO4
Charge Current	225mA nominal
Discharge Current	1A nominal
Charge Voltage Limit	4.0 Volts
Discharge Voltage Limit	2.5 Volts
Ingress Protection	IP20
Battery Weight	0.16Kg
Module Size (L x W x H)	266mm x 33.6mm x 22.5mm
Module Fixing Centers	259mm
Module Weight	0.21Kg
Battery Details (mm)	

Stick 230mm x 24mm x 21mm FC = 220mm

Remote 220.5mm x 32mm x 28.1mm

Cut-out (mm)	40	45	50	53	56	60	65	70	75
Void (mm)	180	150	140	135	130	100	85	80	65

Warning

Avoid running the LED mains driver and emergency pack without the load connected. Failure to do so may result in damage to the LED array

Important

It is recommended that the module is installed by a competent person ensuring the installation complies with the necessary standards. Liteplan accept no responsibility for injury, damage or loss, which may arise as a result of incorrect installation, operation or maintenance.

The conversion requires an unswitched supply for charging the battery and a switched supply if the unit is being used for maintained operation.

ISOLATE BOTH MAINS SUPPLIES AND DISCONNECT THE BATTERY BEFORE INSTALLATION OR MAINTENANCE.

Installation

When converting a luminaire observe the following points:-

1. Ensure that the module and battery pack will operate within their temperature ratings at their chosen location.
2. Ensure that the interconnecting loom is kept as short as possible.
3. Ensure that the Permanent Live & Switched Live feeds are connected correctly.
4. Arrange the wiring to avoid running the 240 Volt cables next to the modules output to the LED to obtain the best EMC results.
5. Requirements for 'F' markings must be observed.
6. Identify clearly the NEW Un-switched supply.
7. Ensure the LED Charge Indicator is clearly visible in every day use.
8. If fitted within a metal enclosure, connect earth terminal to metal gear tray for improved EMC.
9. This module is not intended for use in luminaires for high-risk task area lighting.
10. This module is protected against battery polarity reversal.

Tel +44 (0)1708 372223 | www.liteplan.com | customerservice@liteplan.com | RM3 0AP. UK

Liteplan reserve the right to change colour, price or specification without prior notice

ISS 010726



Installation & Wiring Instructions

TLP/1S/TP40-R

Two Part Remote Conversion Kit



PLEASE READ THESE INSTRUCTIONS BEFORE COMMENCING INSTALLATION & LEAVE WITH END USER

Typical Conversion Wiring Diagram

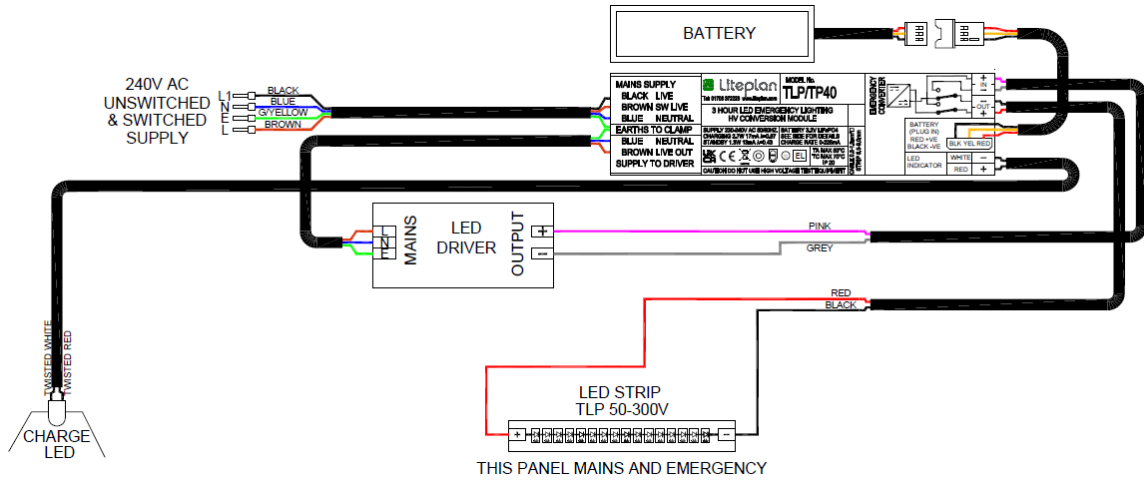

Testing/Commissioning:

- Ensure the load is connected.
- Connect the battery.
- Switch on the Unswitched Supply - Check the Charge LED illuminates.
- Switch on the Maintained Supply - Check the LED illuminates as normal.
- Switch off the Maintained Supply.
- Switch off the Unswitched Supply - Check the Charge LED extinguishes and the load LED illuminates at a reduced output.
- Enter the commissioning date on the Battery Pack. Switch on the Unswitched Supply

Luminaire Ref/Location			In Case of difficulty, contact the Installation Engineers:-							
.....			Tel:.....							
Full Recharge Time 24 Hours			Duration 3 Hours				Lamp Type - LED			
ROUTINE TEST RECORD										
	Year 1		Year 2		Year 3		Year 4		Year 5	
Monthly Test	Signed	Date	Signed	Date	Signed	Date	Signed	Date	Signed	Date
Functional										
Functional										
Functional										
Functional										
Functional										
Functional										
Functional										
Functional										
Functional										
Functional										
Three Hour										

Tel +44 (0)1708 372223 | www.liteplan.com | customerservice@liteplan.com | RM3 0AP. UK

Liteplan reserve the right to change colour, price or specification without prior notice

ISS 010726

