

Installation & Wiring Instructions

ERM/2/MinEM

Non-Maintained Emergency LED Strip



PLEASE READ THESE INSTRUCTIONS BEFORE COMMENCING INSTALLATION & LEAVE WITH END USER

Description:

The ERM/2/MinEM is a simple to install, standalone 3-hour non-maintained emergency LED strip. The LED load emits 150 lumen. The LED strip features a built in indicator LED.

The batteries used with this kit are lithium iron phosphate (LiFePO₄) which not only last double the life of traditional emergency lighting batteries, but consume far less power.

The battery is fitted with a PCM to protect the supply voltage against reverse polarity.

The product features battery temperature protection in accordance with IEC 61347-2-7: 2012+A12:2022.

Specification:

Input Voltage	230-240 Volts AC 50/60 Hz
Input Current & PF - standby	0.6W 10mA - $\lambda = 0.26$
Input Current & PF - charging	1.7W 15mA - $\lambda = 0.47$
Insulation between supply & battery	Double Reinforced
Duration	3-hours
Maximum Module Tc	70°C
Minimum Battery Tc	0°C
Maximum Battery Tc	55°C
Terminal Blocks	0.5-1.5mm ² Push Wire
Battery Fuse	Internal
Battery Discharge Current	150mA Nominal
Discharge Voltage Limit	5.3V
Ingress Protection	IP20
Battery Pack	6.4V 0.6Ah LiFePO ₄
Charge Current	50mA Nominal
Recharge Period	24-Hours
Module Dimensions (LxWxH)	104mm x 29.5mm x 20mm
Module Fixing Centers	97mm
Battery Dimensions (LxWxH)	63mm x 30mm x 16mm
Battery Fixing Point	M4
MinEM Dimensions	46mm x 14mm
Overall Weight	0.10Kg

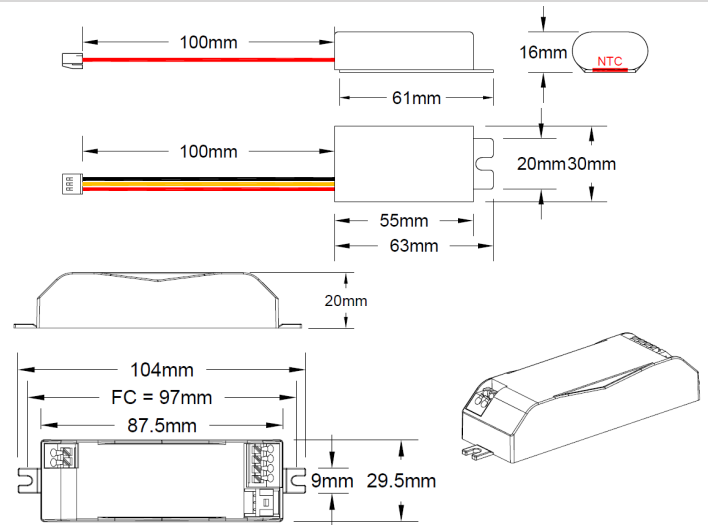

ERM/2/MinEM

Non-Maintained Emergency LED Strip
Open Circuit Voltage (U-OUT) = 10 Volts

Important

It is recommended that the module is installed by a competent person ensuring the installation complies with the necessary standards. Liteplan accept no responsibility for injury, damage or loss, which may arise as a result of incorrect installation, operation or maintenance.

The conversion requires an unswitched supply for charging the battery and a switched supply if the unit is being used for maintained operation.

ISOLATE BOTH MAINS SUPPLIES AND DISCONNECT THE BATTERY BEFORE INSTALLATION OR MAINTENANCE.

Installation

When converting a luminaire observe the following points:-

1. Fit the module & battery pack into the existing luminaire ensuring that they will operate within their temperature ratings.
2. Fix the MinEM LED strip to the geartray of the luminaire, using the two white plastic rivets provided, ensuring that the LED chips and the indicator LED are visible during operation.
3. Wire the module to the MinEM as per wiring diagram on Pg2. A connecting lead measuring 200mm is provided.
4. Ensure that the Permanent Live feed is connected correctly.
5. Arrange the wiring to avoid running the 240 Volt cables next to the modules output to the LED to obtain the best EMC results.
6. Requirements for 'F' markings must be observed.
7. Identify clearly the NEW Un-switched supply.
8. If fitted within a metal luminaire, connect earth terminal to metal gear tray for improved EMC.
9. This module is not intended for use in luminaires for high-risk task area lighting.
10. Once permanent power can be assured, plug the battery into the module.
11. This module is protected against battery polarity reversal.

Installation & Wiring Instructions

ERM/2/MinEM

Non-Maintained Emergency LED Strip



PLEASE READ THESE INSTRUCTIONS BEFORE COMMENCING INSTALLATION & LEAVE WITH END USER

Typical
Conversion
Wiring Diagram

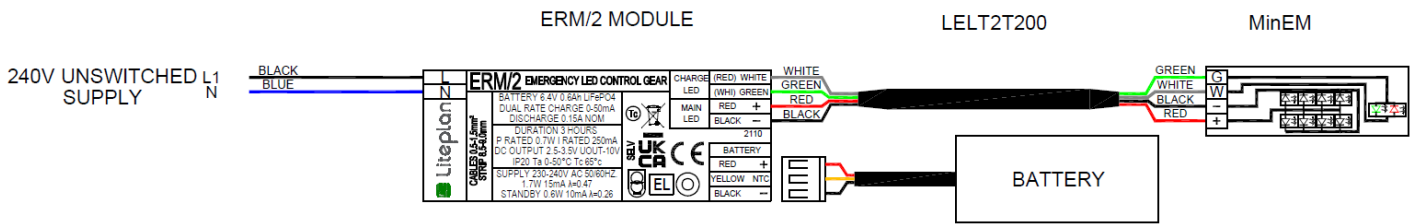

Luminaire Ref/Location			In Case of difficulty, contact the Installation Engineers:- Tel:							
Full Recharge Time 24 Hours			Duration 3 Hours				Lamp Type - LED			
ROUTINE TEST RECORD										
	Year 1		Year 2		Year 3		Year 4		Year 5	
Monthly Test	Signed	Date	Signed	Date	Signed	Date	Signed	Date	Signed	Date
Functional										
Functional										
Functional										
Functional										
Functional										
Functional										
Functional										
Functional										
Functional										
Functional										
Three Hour										

Tel +44 (0)1708 372223 | www.liteplan.com | customerservice@liteplan.com | RM3 0AP. UK

Liteplan reserve the right to change colour, price or specification without prior notice

ISS 080726

