

Technical Specification  
**CE2S/SM** -  
 Suspended Exit Sign  
 with Downlight Panel

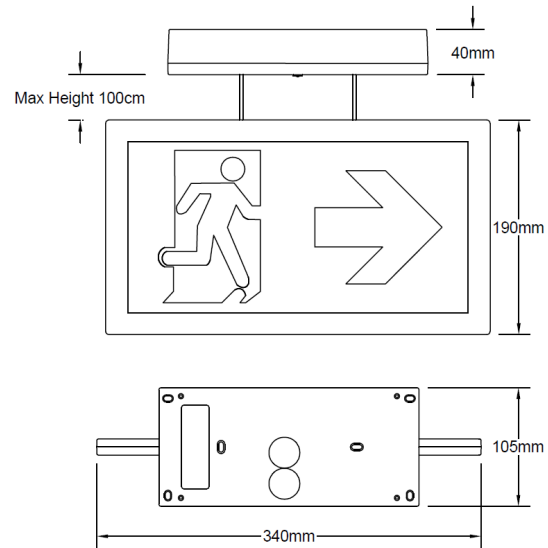

- Basic, DALI-2 or LiteMesh Wireless Operation
- White Polycarbonate Body
- With Additional Downward Facing Light
- Ingress Protection Rating - IP20 rated
- 30m Viewing Distance
- ISO 7010 Legends as Standard
- DDP (Deep Discharge Protection)
- Samsung LED's
- Supplied with a Kit of Legends
- Up to 1000mm Suspension
- TM65.2 Rating of 20.33kg CO<sub>2</sub>e

A stylish and compact suspended Single/Double Sided LED Exit Sign that can be surface mounted.

The unit is available in either a Switchable Maintained/Non-Maintained, DALI-2 Self-Test, or a LiteMesh ready wireless version. The unit comes with a PMMA legend which offers an impressive 30m viewing distance.

The luminaire is supplied with a pack of inlay panels which includes Arrow Down (AD), Arrow Left (AL), Arrow Right (AR) and Arrow up (AU).

The batteries used with this unit not only offer double the life of traditional emergency lighting batteries, but consume far less power during their operation.

## Order Codes

CE2S/SM/M	Switchable Maintained
CE2S/SM/DA	DALI-2 Type B, Switched Maintained, Non-Dimmable, or Self-Test M3/NM3
CE2S/SM/LMEM	LiteMesh Wireless Self-Test Switched Maintained/Non-Maintained

## Technical Details:

	CE2S/SM/M	CE2S/SM/DA
Mains Supply	230-240V AC 50/60 Hz	
Power Rating - Charging - Maintained*	5.7W 31mA $\lambda = 0.75$	5W 28mA $\lambda = 0.74$
Power Rating - Charged*	0.2W 8mA $\lambda = 0.11$	0.26W 8mA $\lambda = 0.14$
Duration	3-Hours	
Recharge Period	24-Hours	
Battery Size & Type	3.2V 3.8Ah LiFePO <sub>4</sub> Cell	
Charge Current	225mA nominal	
Ingress Protection Rating	IP40	
Weight	1.2Kg	

\* Following its initial charge, the unit will spend 90% of its operational life in standby mode