

PLEASE READ THESE INSTRUCTIONS BEFORE COMMENCING INSTALLATION & LEAVE WITH END USER

Description:

The Liteplan D2N/1 DALI-2 self-test emergency lighting modules are designed to convert a wide range of LED types with one main version. The D2N/1 is the popular choice for converting most standard LED luminaires and arrays between 6 and 55 Volts.

The modules are designed to be installed by breaking into the low voltage connection between the mains driver and the LEDs and allows the LEDs to be operated as normal under mains healthy conditions and operated at reduced light output in an emergency.

The module automatically adjusts the output LED current to provide the best match between the battery and the load, providing maximum illumination whilst ensuring full battery duration and are compatible with a wide range of lighting.

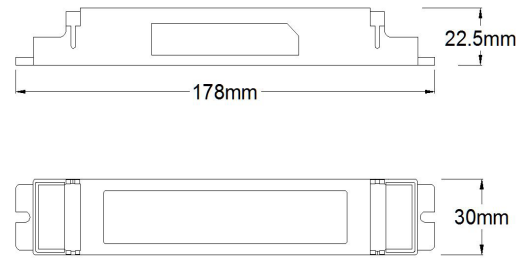

Fixing Centres 172mm

D2N/1

Rated - 2.2W
 Rated - 352mA - 40mA
 Voltage Range 6 - 55 Volts
 Open Circuit Voltage (U-OUT) = 60 Volts

Specification:

Input Voltage	230-240 Volts AC 50/60 Hz
Power Rating (charging)	2.8W 17mA - $\lambda = 0.70$
Power Rating (charged)	1.4W 12mA - $\lambda = 0.48$
Duration	3-Hours
Ambient Temperature	0°C to + 50°C
Max Case Temperature	70°C
Max Battery Temperature	55°C
Terminal Blocks	0.5-1.5mm ² Push Fit
Battery Fuse	Internal
Battery Discharge Current	900mA nominal
Discharge Voltage DDP	2.4V
Ingress Protection	IP20
Battery Pack	3.2V 3.8Ah LiFePO ₄
Charge Current	225mA nominal
Recharge Period	24-Hours
Module Size (L x W x H)	178mm x 30mm x 22.5mm
Module Fixing Centers	172mm
Module Weight	0.1Kg
Battery Weight	0.11Kg
Battery Dimensions	90mm x 28mm diameter
Insulation between Supply & Battery	Double Reinforced

Warning

Avoid running the LED mains driver and emergency pack without the load connected. Failure to do so may result in damage to the LED array

Important

It is recommended that the module is installed by a competent person ensuring the installation complies with the necessary standards. Liteplan accept no responsibility for injury, damage or loss, which may arise as a result of incorrect installation, operation or maintenance.

The conversion requires an unswitched supply for charging the battery and a switched supply if the unit is being used for maintained operation.

ISOLATE BOTH MAINS SUPPLIES AND DISCONNECT THE BATTERY BEFORE INSTALLATION OR MAINTENANCE.

Installation

When converting a luminaire observe the following points:-

1. Fit the module & battery pack into the existing luminaire ensuring that they will operate within their temperature ratings.
2. If the module & battery pack do not fit integrally, then a remote conversion can be used. Ensure that the interconnecting loom is kept as short as possible.
3. Wire the module & battery into the luminaire as per wiring diagram on Pg2.
4. Ensure that the Permanent Live & Switched Live feeds are connected correctly.
5. Ensure that the DALI pair is connected to the DALI operating system
6. Arrange the wiring to avoid running the 240 Volt cables next to the modules output to the LED to obtain the best EMC results.
7. Requirements for 'F' markings must be observed.
8. Identify clearly the NEW Un-switched supply.
9. Ensure the LED Charge Indicator is clearly visible.
10. If fitted within a metal enclosure, connect earth terminal to metal gear tray for improved EMC.
11. This module is not intended for use in luminaires for high-risk task area lighting.
12. This module is protected against battery polarity reversal.

Installation & Wiring Instructions

D2N/1 DALI-2 Self-Test Conversion Kit



PLEASE READ THESE INSTRUCTIONS BEFORE COMMENCING INSTALLATION & LEAVE WITH END USER

Typical
Conversion
Wiring Diagram

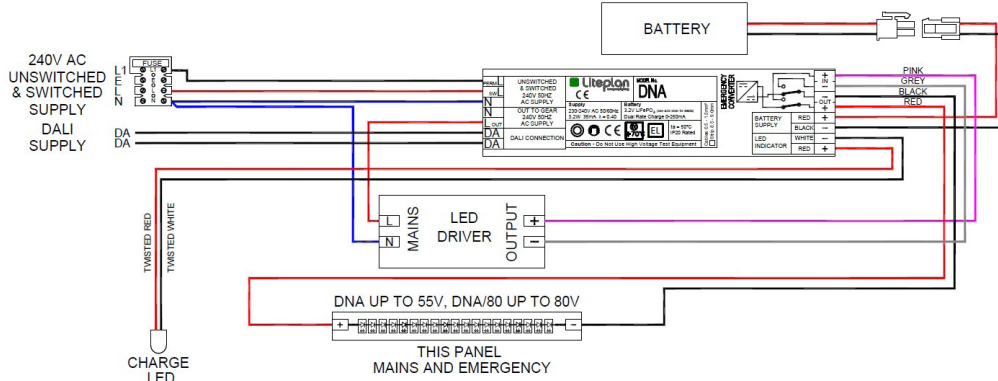

Device Status Indicator:

Green Solid		Battery connected & charging	Red Fast Flash 2 x 0.5 sec On, 2.5 sec Off	Lamp Fault
Green Flash	2.0 sec On, 0.2 sec Off	48h Pre-Commissioning	Red Slow Flash 0.5 sec On, 3.5 sec Off	Battery Fault
Green Flash	0.2 sec On, 2.0 sec Off	Function Test in progress	Red / Green Alternating	Identification Mode
Green Flash	0.2 sec On, 2.0 sec Off	Duration Test in progress	Red & Green Off	In Emergency Mode

Luminaire Ref/Location		In Case of difficulty, contact the Installation Engineers:- Tel:								
Full Recharge Time 24 Hours		Duration 3 Hours				Lamp Type - LED				
ROUTINE TEST RECORD										
	Year 1		Year 2		Year 3		Year 4		Year 5	
	Signed	Date	Signed	Date	Signed	Date	Signed	Date	Signed	Date
Monthly Test										
Functional										
Functional										
Functional										
Functional										
Functional										
Functional										
Functional										
Functional										
Functional										
Functional										
Three Hour										

Tel +44 (0)1708 372223 | www.liteplan.com | customerservice@liteplan.com | RM3 0AP. UK

Liteplan reserve the right to change colour, price or specification without prior notice

ISS 180324

