

Technical Specification

NLP/2/SP85-R - High Output Remote Conversion Range

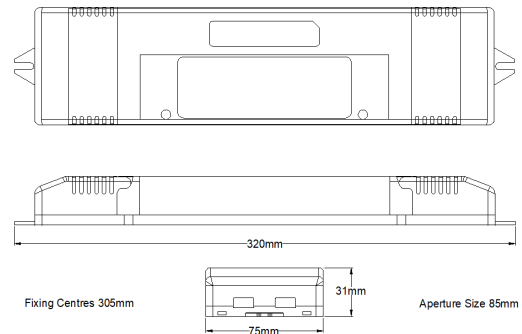

The NLP/2/SP85-R is supplied as a remote conversion kit designed to be mounted adjacent to the luminaire, where room inside the fitting is limited. This part offers a higher output which is more suitable for higher power luminaires.

- Single Piece Remote Enclosure
- Deep Discharge Protection
- Low Power Consumption
- Long Life LiFePO4 Batteries
- Average Emergency Power - 4.8W
- 3rd Party Tested and Certified by TÜV

A 3 hour emergency lighting conversion kit which operates with Long Life LiFePO4 batteries. The unit is designed to suit an extremely wide range of LED types and circuits. The NLP/2/SP85-R automatically adjusts the output LED current to provide the best match between the battery and the load, providing maximum illumination whilst ensuring full battery duration.

There are 2 main versions available -

The batteries used with this unit not only provide double the life of traditional emergency lighting batteries, but consume far less power during their operational life.

Order Codes

NLP/2/SP85-R For LED loads operating in the Voltage range of 10 - 55 Volts.
For remote use

NLP/2/80/SP85-R For LED loads operating in the Voltage range of 10 - 80 Volts.
For remote use

Technical Details:

Mains Supply	230-240V AC 50/60 Hz	Max Ta and Tc	Ta - 50 °C - Tc - 70 °C
Power Rating (charging)*	3.8W 23mA $\lambda = 0.69$	Max Battery Temperature	55 °C
Power Rating (standby)*	1.3W 13mA $\lambda = 0.43$	Duration	3-Hours
Battery Discharge Current	900mA nominal	Charge Current	225mA Nominal
Recharge Period	24-Hours	Discharge Voltage Limit	5.0 Volts
Battery Size & Type	6.4V 3.8Ah LiFePO4 Cell	Ingress Protection	IP20
Terminal - Push Wire	0.5mm ² - 1.5 mm ²	Weight	0.1Kg
		Module Dimensions (LxWxH)	320mm x 75mm x 31mm

* Following its initial charge, the NLP/2/SP85 module will spend 90% of its operational life in standby mode.